

Diaphragm seal for Pressure Instrument

Model: P790 series

Spec. sheet no. PD07-10

Service intended

P790 series diaphragm seal are suitable for conditions where the process medium can cause corrosion to the instrument connection and the pressure sensing element, which the process medium contains suspended solid particles are viscous and be closed. It is also suitable for where the process medium can freeze or solidify the internal parts of the instrument and where the medium requires flushing from the system to prevent contamination.

Design

Instrument welded diaphragm with threaded process connection, require hydraulic fluid to transmitter pressure to instrument.

Filling liquid

Silicone oil

Working temperature

Ambient : -20 ~ 65 °C

Fluid : Refer to filling liquid reference table

Diaphragm material

Diaphragms are available in many corrosion resistant materials. Compatibility of selected material and process fluid should be determined by the user

Temperature effect

Accuracy at temperature above and below the reference temperature (20 °C) will be effected by approximately $\pm 0.5\%$ per 10 °C of full scale



Standard features

Upper flange (Gauge side)

Stainless steel (304, 316), Titanium, Monel

Capillary

Capillary : $\text{Ø}3.0$ mm, 316L

Flexible tube : $\text{Ø}7.5$ mm, 304, PVC coated

Diaphragm material

Stainless steel(316L)

Hastelloy C-276, Titanium,

Tantalum, Monel

Pressure connection

Thread type : PT, PF, and NPT others feasible

Flange type : ANSI(ASME), JIS or other standard

Note

PTFE lining is available up to 7 MPa (Coating)

1. Base model

- P791** Diaphragm seal for gauge pressure
P792 Diaphragm seal for differential pressure

2(11). High pressure side flange configuration

- 1** Thread connector type (Figure A)
2 "I" flange type (Figure B)
3 Flat flange type (Figure C,D)
4 Wafer type (Figure E)
5 Flush diaphragm type (Figure F,G)
6 Extended diaphragm type (Figure H,I)

3(12). Upper flange and Diaphragm material

- B** 304SS and 316L SS
E 316SS and 316L SS
G Monel and Monel
H 304SS and 316L SS + PTFE sheet
 (Only available to figure A, B, C and D)
L 316SS and Hastelloy C-276
N 316SS and Tantalum
Q 316SS and 316L SS + PTFE sheet
 (Only available to figure A, B, C and D)
R Titanium and Titanium
Z Other

4(13). Process connection

- XXX** Refer to process connection type table

5(14). Under flange material

- XX** None (Only available to figure E,F,G,H and I)
BX 304SS
CX 316SS
DX 304L SS
EX 316L SS
KX Hastelloy C-276
LX Monel
MX Titanium
PX 304SS + PTFE lining (Only available to figure B,C and D)
SX 316SS + PTFE coating
50 316L SS + PTFE lining (Only available to figure B,C and D)
ZZ Other

6(15). Extended length (mm), Only available to figure H and I

- 1** None
2 50
3 100
4 150
5 200
6 Other

7(16). Flexible tube length (m)

- A** None
Q 3
R 4
S 5
T 6
U 7
Y 8
W 9
X 10
Z Other

8. Filling liquid

- X** Refer to filling liquid reference table

9(17). Option

- A** None
B Flushing ring (Not available with figure E,H and I)
C Flushing ring + Isolation valve
 (Not available with figure E,H and I)

10. Low pressure side flange configuration

- 0** None (Gauge pressure, Single diaphragm seal for differential pressure)
1 Identical to high pressure side flange configuration
2 Different from high pressure side flange configuration
 (See note)

Note :

Please, enter the ordering code consecutively from No.11.
 Refer to sample ordering code.

Sample ordering code

1	2	3	4	5	6	7	8	9	10	11
P792	2	E	XXX	EX	1	Q	X	A	2	5
12	13	14	15	16	17					
E	XXX	XX	1	A	A					

Figure "A"

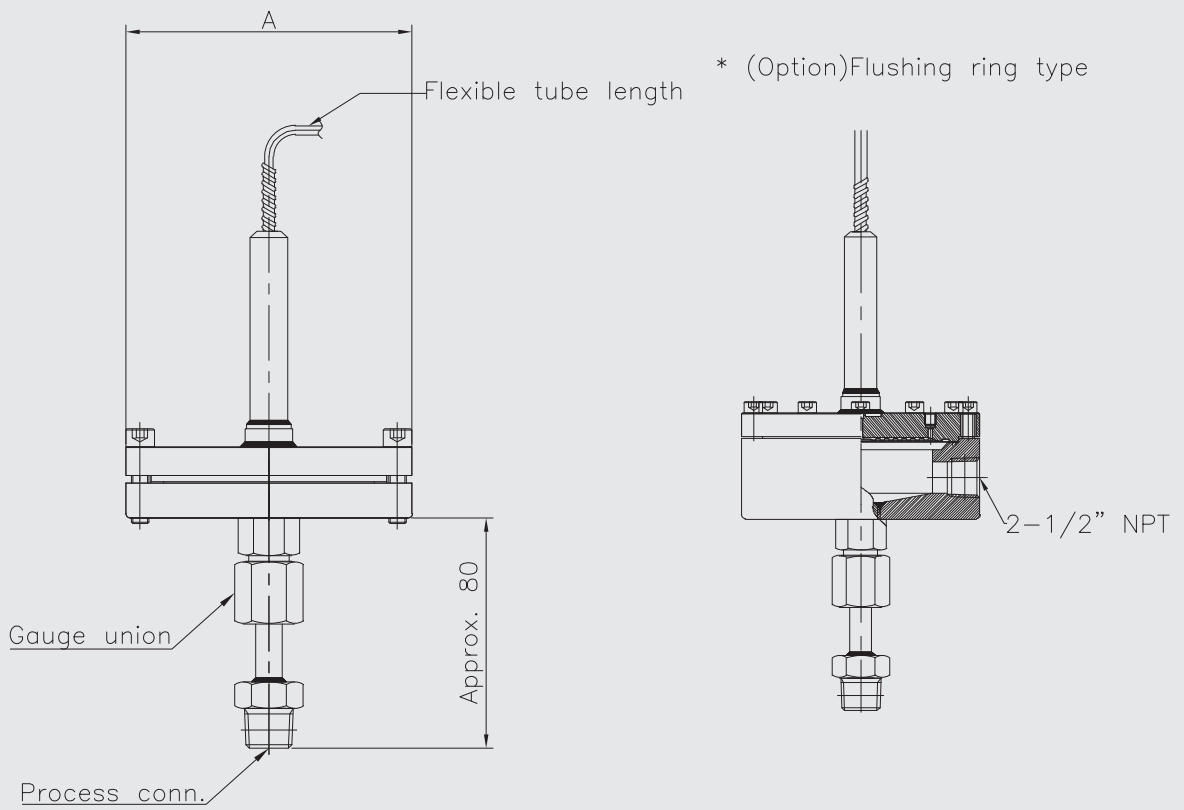

Dimensions (mm)

Pressure rating	Diaphragm	A*	Remark
Over 10 MPa	Ø59	100	
Over 10 kPa	Ø70	110	
Over 5 kPa	Ø89	130	

* "A" may be change depending on pressure rating.

Figure "B"

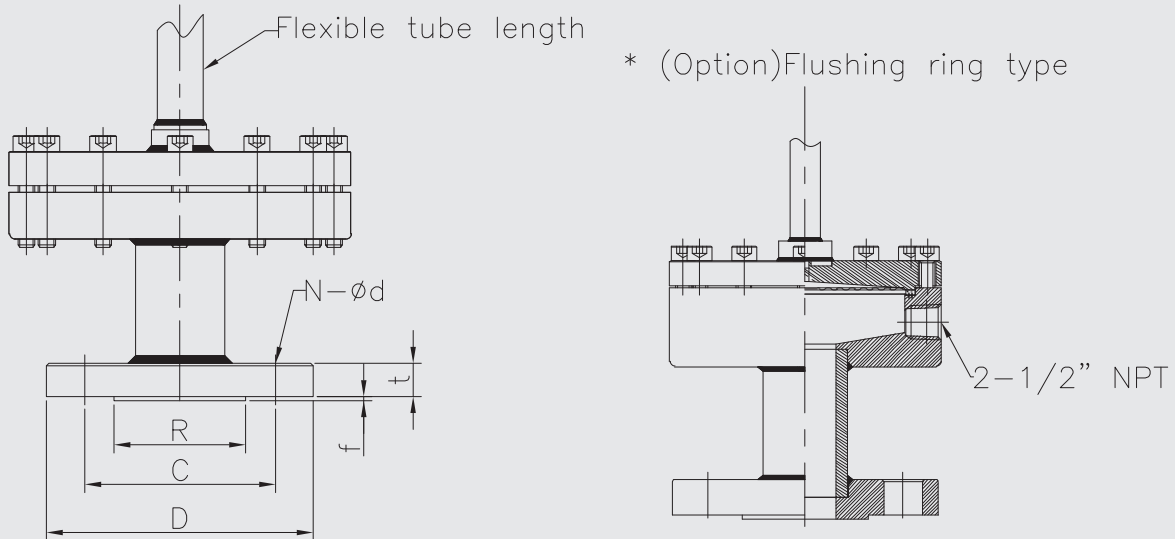

Dimensions (mm)

Flange rating		Diaphragm	D	C	R	f	t	N	d
ASME	1"	CLASS 150	110	79.4	50.8	2	12.7	4	16
	1 1/2"		125	98.4	73.0	2	15.9	4	16
	2"		150	120.7	92.1	2	17.5	4	19
	3"		190	152.4	127.0	2	22.3	4	19
	4"		230	190.5	157.2	2	22.3	8	19
	1"	CLASS 300	125	88.9	50.8	2	15.9	4	19
	1 1/2"		155	114.3	73.0	2	19.1	4	22
	2"		160	127	92.1	2	20.7	8	19
	3"		210	168.3	127.0	2	27	8	22
	4"		255	200	157.2	2	30.2	8	22
	1"	CLASS 400(600)	125	88.9	50.8	7	17.5	4	19
	1 1/2"		155	114.3	73.0	7	22.3	4	22
	2"		165	127	92.1	7	25.4	8	19
	3"		210	168.3	127.0	7	35	8	22
	4"		255	200	157.2	7	35	8	25
	1"	CLASS 400	275	215.9	157.2	7	38.1	8	25
	4"		150	101.6	50.8	7	28.6	4	25
	1 1/2"	CLASS 900(1500)	180	123.8	73.0	7	31.8	4	29
	2"		215	165.1	92.1	7	38.1	8	25
	3"	CLASS 900	240	190.5	127.0	7	38.1	8	25
	4"		290	235	157.2	7	44.5	8	32
	3"	CLASS 1500	265	203.2	127.0	7	47.7	8	32
	4"		310	241.3	157.2	7	54	8	35
	1"	CLASS 2500	160	108	50.8	7	35	4	25
1 1/2"	205		146	73.0	7	44.5	4	32	
2"	235		171.4	92.1	7	50.9	8	29	
3"	305		228.6	127.0	7	66.7	8	35	
4"	355		273	157.2	7	76.2	8	42	

P790X : Type of mounting (3/10)

Dimensions			(mm)							
Flange rating			Diaphragm	D	C	R	f	t	N	d
JIS	25A	5K	Ø70, Ø89	95	75	59	1	9	4	12
	40A			120	95	75	2	10	4	15
	50A			130	105	85	2	12	4	15
	80A			180	145	121	2	12	4	19
	100A			200	165	141	2	14	8	19
	25A	10K		125	90	67	1	13	4	19
	40A			140	105	81	2	14	4	19
	50A			155	120	85	2	14	4	19
	80A			185	150	126	2	16	8	19
	100A			210	175	151	2	16	8	19
	25A	16K		125	90	67	1	13	4	19
	40A			140	105	81	2	14	4	19
	50A			155	120	96	2	14	8	19
	80A			200	160	132	2	18	8	23
	100A			225	185	160	2	20	8	23
	25A	20K		125	90	67	1	15	4	19
	40A			140	105	81	2	16	4	19
	50A			155	120	96	2	16	8	19
	80A			200	160	132	2	20	8	23
	100A			225	185	160	2	22	8	23
	25A	30K		130	95	70	1	19	4	19
	40A			160	120	90	2	20	4	23
	50A			165	130	105	2	20	8	19
	80A			210	170	140	2	26	8	23
	100A			240	195	160	2	30	8	25
	25A	40K		130	95	70	1	21	4	19
	40A			160	120	90	2	22	4	23
	50A			165	130	105	2	24	8	19
	80A			210	170	140	2	30	8	23
	100A			250	205	165	2	34	8	25
25A	63K	140	100	70	1	26	4	23		
40A		175	130	90	2	30	4	25		
50A		185	145	105	2	32	8	23		
80A		230	185	140	2	38	8	25		
100A		270	220	165	2	42	8	27		

Dimensions			(mm)							
Flange rating			Diaphragm	D	C	R	f	t	N	d
DIN	DN25	6 bar	Ø70, Ø89	100	75	60	2	12	4	11.5
	DN40			130	100	80	3	13	4	14
	DN50			140	110	90	3	13	4	14
	DN80			190	150	128	3	13	4	18
	DN100			210	170	148	3	13	4	18
	DN25	10 bar		115	85	68	2	14	4	14
	DN40			150	110	88	3	13	4	18
	DN50			165	125	102	3	15	4	18
	DN80			200	160	138	3	17	4	18
	DN100			220	180	158	3	17	8	18
	DN25	16 bar		115	85	68	2	14	4	14
	DN40			150	110	88	3	13	4	18
	DN50			165	125	102	3	15	4	18
	DN80			200	160	138	3	17	8	18
	DN100			220	180	158	3	17	8	18
	DN25	25 bar		115	85	68	2	16	4	14
	DN40			150	110	88	3	15	4	18
	DN50			165	125	102	3	17	4	18
	DN80			200	160	138	3	21	8	18
	DN100			235	190	162	3	21	8	22
	DN25	40 bar		115	85	68	2	16	4	14
	DN40			150	110	88	3	15	4	18
	DN50			165	125	102	3	17	4	18
	DN80			200	160	138	3	21	8	18
	DN100			235	190	162	3	21	8	23

Figure "C"

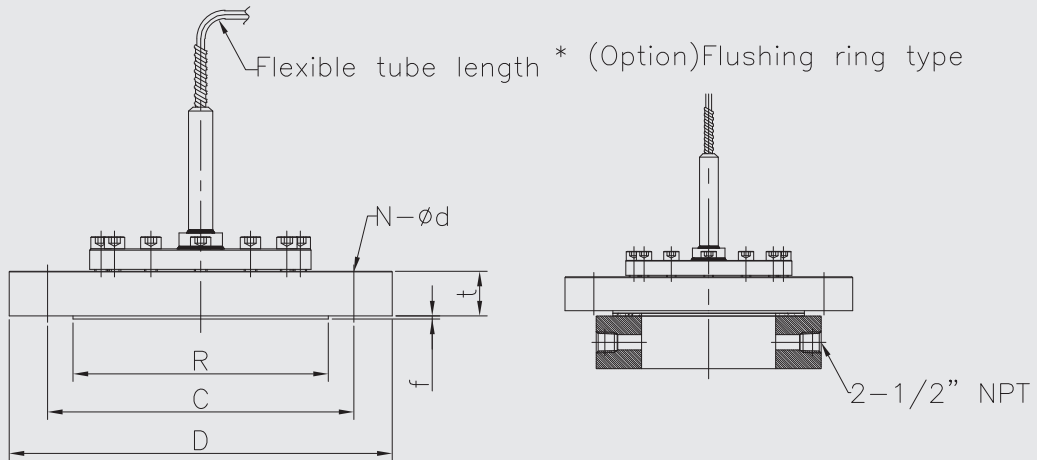
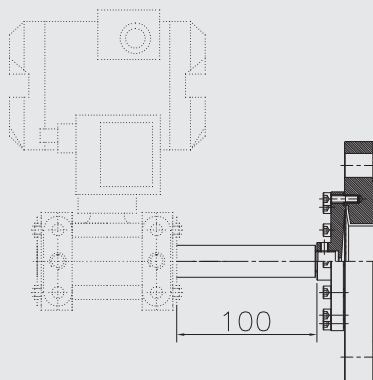

Figure "D"



P790X : Type of mounting (5/10)

Dimensions (mm)										
	Flange rating		Diaphragm	D	C	R	f	t	N	d
ASME	1 1/2"	CLASS 150	Ø70	125	98.4	73.0	2	15.9	4	16
	2"			150	120.7	92.1	2	17.5	4	19
	3"		Ø89	190	152.4	127.0	2	22.3	4	19
	4"			230	190.5	157.2	2	22.3	8	19
	1 1/2"	CLASS 300	Ø70	155	114.3	73.0	2	19.1	4	22
	2"			160	127	92.1	2	20.7	8	19
	3"		Ø89	210	168.3	127.0	2	27	8	22
	4"			255	200	157.2	2	30.2	8	22
	1 1/2"	CLASS 400(600)	Ø70	155	114.3	73.0	7	22.3	4	22
	2"			165	127	92.1	7	25.4	8	19
	3"		Ø89	210	168.3	127.0	7	35	8	22
	4"			255	200	157.2	7	35	8	25
	4"	CLASS 400	Ø89	275	215.9	157.2	7	38.1	8	25
	4"	CLASS 600		180	123.8	73.0	7	31.8	4	29
	1 1/2"	CLASS 900(1500)	Ø70	215	165.1	92.1	7	38.1	8	25
	2"			240	190.5	127.0	7	38.1	8	25
	3"	CLASS 900	Ø89	290	235	157.2	7	44.5	8	32
	4"			265	203.2	127.0	7	47.7	8	32
	3"	CLASS 1500	Ø89	310	241.3	157.2	7	54	8	35
	4"			205	146	73.0	7	44.5	4	32
1 1/2"	CLASS 2500	Ø70	235	171.4	92.1	7	50.9	8	29	
2"			305	228.6	127.0	7	66.7	8	35	
3"		Ø89	355	273	157.2	7	76.2	8	42	
4"										

Dimensions (mm)										
	Flange rating		Diaphragm	D	C	R	f	t	N	d
JIS	50A	5K	Ø70	130	105	85	2	12	4	15
	80A			180	145	121	2	12	4	19
	100A		Ø89	200	165	141	2	14	8	19
	50A	10K		Ø70	155	120	85	2	14	4
	80A		185		150	126	2	16	8	19
	100A		Ø89	210	175	151	2	16	8	19
	50A	16K		Ø70	155	120	96	2	14	8
	80A		Ø89		200	160	132	2	18	8
	100A			225	185	160	2	20	8	23
	50A	20K	Ø70	155	120	96	2	16	8	19
	80A			Ø89	200	160	132	2	20	8
	100A		225		185	160	2	22	8	23
	50A	30K	Ø70	165	130	105	2	20	8	19
	80A			Ø89	210	170	140	2	26	8
	100A		240		195	160	2	30	8	25
	50A	40K	Ø70	165	130	105	2	24	8	19
	80A			Ø89	210	170	140	2	30	8
	100A		250		205	165	2	34	8	25
	50A	63K	Ø70	185	145	105	2	32	8	23
	80A			Ø89	230	185	140	2	38	8
	100A		270		220	165	2	42	8	27

Dimensions (mm)										
	Flange rating		Diaphragm	D	C	R	f	t	N	d
DIN	DN50	6 bar	Ø70	140	110	90	3	13	4	14
	DN80			190	150	128	3	13	4	18
	DN100		Ø89	210	170	148	3	13	4	18
	DN50	10 bar		Ø70	165	125	102	3	15	4
	DN80		Ø89		200	160	138	3	17	4
	DN100			220	180	158	3	17	8	18
	DN50	16 bar	Ø70	165	125	102	3	15	4	18
	DN80			Ø89	200	160	138	3	17	8
	DN100		220		180	158	3	17	8	18
	DN50	25 bar	Ø70	165	125	102	3	17	4	18
	DN80			Ø89	200	160	138	3	21	8
	DN100		235		190	162	3	21	8	22
	DN50	40 bar	Ø70	165	125	102	3	17	4	18
	DN80			Ø89	200	160	138	3	21	8
	DN100		235		190	162	3	21	8	23

P790X : Type of mounting (6/10)

Figure "E"

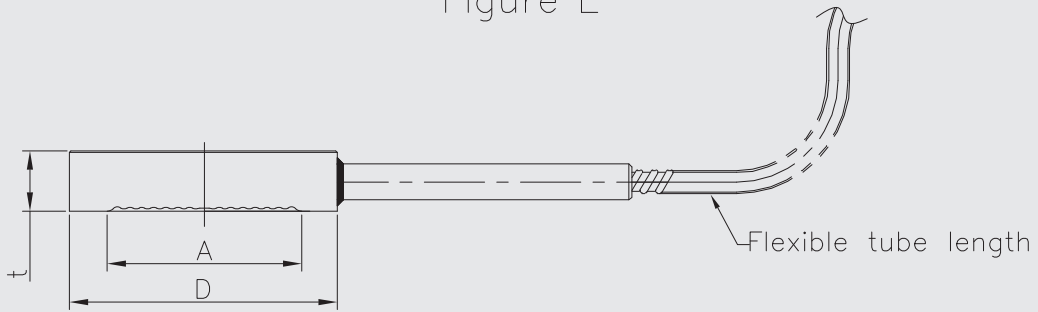

Dimensions (mm)

Flange rating		A	D	t	
ASME	2"	CLASS 150	Ø59	104	20
	3"		Ø70	136	20
	4"		Ø89	174	20
	2"	CLASS 300	Ø59	111	20
	3"		Ø70	149	20
	4"		Ø89	181	20
	2"	CLASS 400(600)	Ø59	111	20
	3"		Ø70	149	20
	4"	CLASS 400	Ø89	177	20
	4"	CLASS 600	Ø89	193	20
	2"	CLASS 900(1500)	Ø59	143	20
	3"	CLASS 900	Ø70	168	20
	4"		Ø89	206	20
	3"	CLASS 1500	Ø70	174	20
	4"		Ø89	209	20
2"	CLASS 2500	Ø59	146	20	
3"		Ø70	196	20	
4"		Ø89	235	20	

Dimensions (mm)

Flange rating		A	D	t	
JIS	50A	5K	Ø59	92	20
	80A		Ø70	128	20
	100A		Ø89	148	20
	50A	10K	Ø59	103	20
	80A		Ø70	133	20
	100A		Ø89	158	20
	50A	16K	Ø59	103	20
	80A		Ø70	139	20
	100A		Ø89	164	20
	50A	20K	Ø59	103	20
	80A		Ø70	139	20
	100A		Ø89	164	20
	50A	30K	Ø59	113	20
	80A		Ø70	149	20
	100A		Ø89	172	20
	50A	40K	Ø59	113	20
	80A		Ø70	149	20
	100A		Ø89	182	20
	50A	63K	Ø59	124	20
	80A		Ø70	162	20
	100A		Ø89	195	20

Dimensions (mm)

Flange rating		A	D	t	
DIN	DN50	6 bar	Ø59	98	20
	DN80		Ø70	134	20
	DN100		Ø89	154	20
	DN50	10 bar	Ø59	109	20
	DN80		Ø70	144	20
	DN100		Ø89	164	20
	DN50	16 bar	Ø59	109	20
	DN80		Ø70	144	20
	DN100		Ø89	164	20
	DN50	25 bar	Ø59	109	20
	DN80		Ø70	144	20
	DN100		Ø89	170	20
	DN50	40 bar	Ø59	109	20
	DN80		Ø70	144	20
	DN100		Ø89	169	20

Figure "F"

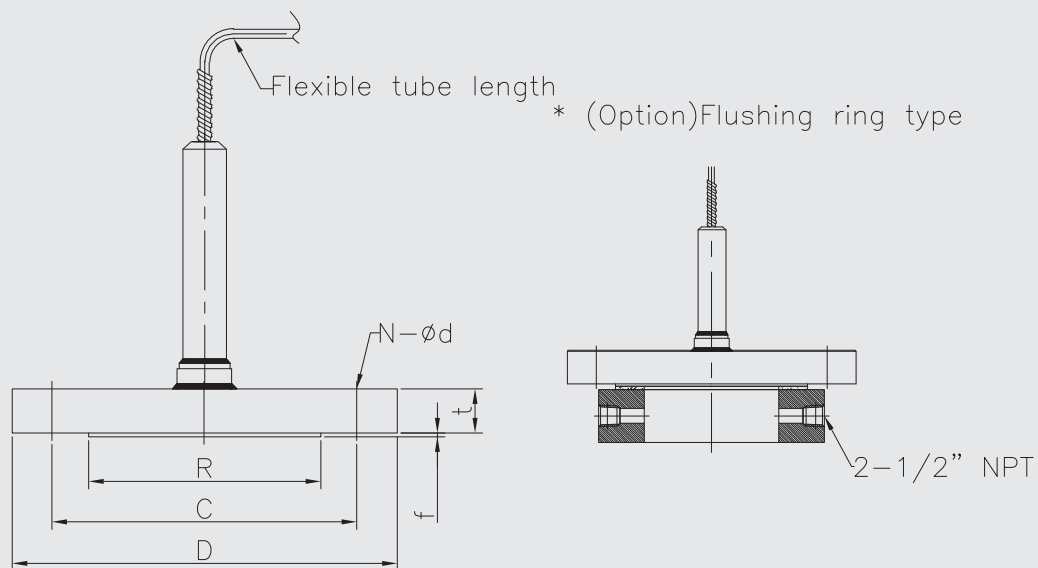
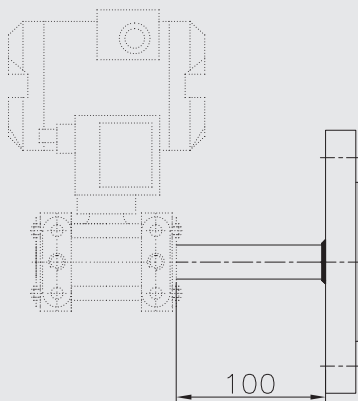

Figure "G"



P790X : Type of mounting (8/10)

Dimensions (mm)

Flange rating		Diaphragm	D	C	R	f	t	N	d	
ASME	2"	CLASS 150	Ø59	150	120.7	92.1	2	17.5	4	19
	3"		Ø89	190	152.4	127.0	2	22.3	4	19
	4"		230	190.5	157.2	2	22.3	8	19	
	2"	CLASS 300	Ø59	160	127	92.1	2	20.7	8	19
	3"		Ø89	210	168.3	127.0	2	27	8	22
	4"		255	200	157.2	2	30.2	8	22	
	2"	CLASS 400(600)	Ø59	165	127	92.1	7	25.4	8	19
	3"		Ø89	210	168.3	127.0	7	35	8	22
	4"		255	200	157.2	7	35	8	25	
	4"	CLASS 600	Ø89	275	215.9	157.2	7	38.1	8	25
	2"	CLASS 900(1500)	Ø59	215	165.1	92.1	7	38.1	8	25
	3"	CLASS 900	Ø89	240	190.5	127.0	7	38.1	8	25
	4"			290	235	157.2	7	44.5	8	32
	3"			265	203.2	127.0	7	47.7	8	32
	4"	CLASS 1500	Ø89	310	241.3	157.2	7	54	8	35
	2"	CLASS 2500	Ø59	235	171.4	92.1	7	50.9	8	29
3"	Ø89		305	228.6	127.0	7	66.7	8	35	
4"	355		273	157.2	7	76.2	8	42		

Dimensions (mm)

Flange rating		Diaphragm	D	C	R	f	t	N	d	
JIS	50A	5K	Ø59	130	105	85	2	12	4	15
	80A		Ø89	180	145	121	2	12	4	19
	100A		200	165	141	2	14	8	19	
	50A	10K	Ø59	155	120	85	2	14	4	19
	80A		Ø89	185	150	126	2	16	8	19
	100A		210	175	151	2	16	8	19	
	50A	16K	Ø59	155	120	96	2	14	8	19
	80A		Ø89	200	160	132	2	18	8	23
	100A		225	185	160	2	20	8	23	
	50A	20K	Ø59	155	120	96	2	16	8	19
	80A		Ø89	200	160	132	2	20	8	23
	100A		225	185	160	2	22	8	23	
	50A	30K	Ø59	165	130	105	2	20	8	19
	80A		Ø89	210	170	140	2	26	8	23
	100A		240	195	160	2	30	8	25	
	50A	40K	Ø59	165	130	105	2	24	8	19
	80A		Ø89	210	170	140	2	30	8	23
	100A		250	205	165	2	34	8	25	
	50A	63K	Ø59	185	145	105	2	32	8	23
	80A		Ø89	230	185	140	2	38	8	25
	100A		270	220	165	2	42	8	27	

Dimensions (mm)

Flange rating		Diaphragm	D	C	R	f	t	N	d	
DIN	DN50	6 bar	Ø59	140	110	90	3	13	4	14
	DN80		Ø89	190	150	128	3	13	4	18
	DN100		210	170	148	3	13	4	18	
	DN50	10 bar	Ø59	165	125	102	3	15	4	18
	DN80		Ø89	200	160	138	3	17	4	18
	DN100		220	180	158	3	17	8	18	
	DN50	16 bar	Ø59	165	125	102	3	15	4	18
	DN80		Ø89	200	160	138	3	17	8	18
	DN100		220	180	158	3	17	8	18	
	DN50	25 bar	Ø59	165	125	102	3	17	4	18
	DN80		Ø89	200	160	138	3	21	8	18
	DN100		235	190	162	3	21	8	22	
	DN50	40 bar	Ø59	165	125	102	3	17	4	18
	DN80		Ø89	200	160	138	3	21	8	18
	DN100		235	190	162	3	21	8	23	

Figure "H"

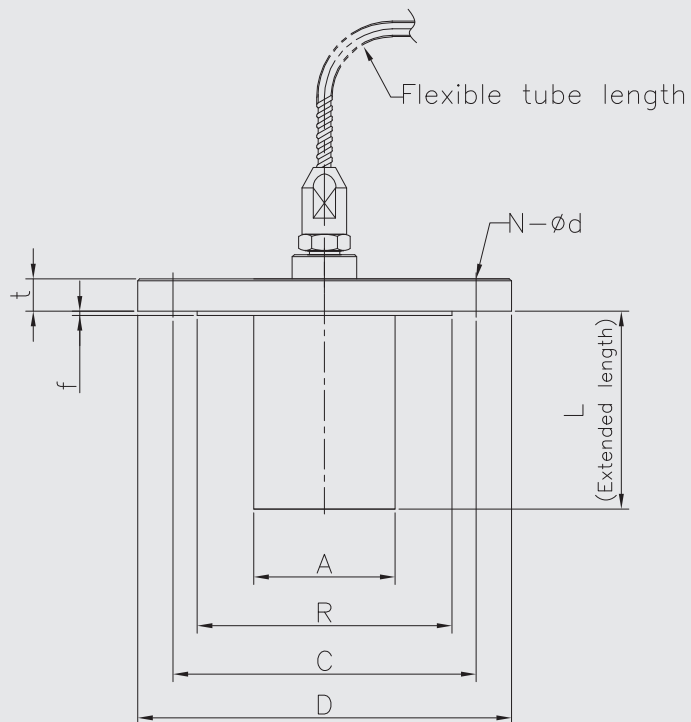
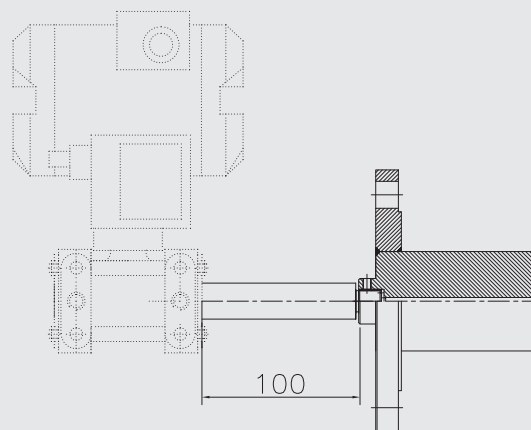

Figure "I"



P790X : Type of mounting (10/10)

Dimensions (mm)

Flange rating		A	D	C	R	f	t	N	d	
ASME	2"	CLASS 150	Ø60	150	120.7	92.1	2	17.5	4	19
	3"		Ø71	190	152.4	127.0	2	22.3	4	19
	4"		Ø90	230	190.5	157.2	2	22.3	8	19
	2"	CLASS 300	Ø60	160	127	92.1	2	20.7	8	19
	3"		Ø71	210	168.3	127.0	2	27	8	22
	4"		Ø90	255	200	157.2	2	30.2	8	22
	2"	CLASS 400(600)	Ø60	165	127	92.1	7	25.4	8	19
	3"		Ø71	210	168.3	127.0	7	35	8	22
	4"	CLASS 400	Ø90	255	200	157.2	7	35	8	25
	4"	CLASS 600	Ø90	275	215.9	157.2	7	38.1	8	25
	2"	CLASS 900(1500)	Ø60	215	165.1	92.1	7	38.1	8	25
	3"	CLASS 900	Ø71	240	190.5	127.0	7	38.1	8	25
	4"		Ø90	290	235	157.2	7	44.5	8	32
	3"	CLASS 1500	Ø71	265	203.2	127.0	7	47.7	8	32
	4"		Ø90	310	241.3	157.2	7	54	8	35
	2"	CLASS 2500	Ø60	235	171.4	92.1	7	50.9	8	29
3"	Ø71		305	228.6	127.0	7	66.7	8	35	
4"	Ø90		355	273	157.2	7	76.2	8	42	

Dimensions (mm)

Flange rating		A	D	C	R	f	t	N	d	
JIS	50A	5K	Ø60	130	105	85	2	12	4	15
	80A		Ø71	180	145	121	2	12	4	19
	100A		Ø90	200	165	141	2	14	8	19
	50A	10K	Ø60	155	120	85	2	14	4	19
	80A		Ø71	185	150	126	2	16	8	19
	100A		Ø90	210	175	151	2	16	8	19
	50A	16K	Ø60	155	120	96	2	14	8	19
	80A		Ø71	200	160	132	2	18	8	23
	100A		Ø90	225	185	160	2	20	8	23
	50A	20K	Ø60	155	120	96	2	16	8	19
	80A		Ø71	200	160	132	2	20	8	23
	100A		Ø90	225	185	160	2	22	8	23
	50A	30K	Ø60	165	130	105	2	20	8	19
	80A		Ø71	210	170	140	2	26	8	23
	100A		Ø90	240	195	160	2	30	8	25
	50A	40K	Ø60	165	130	105	2	24	8	19
	80A		Ø71	210	170	140	2	30	8	23
	100A		Ø90	250	205	165	2	34	8	25
	50A	63K	Ø60	185	145	105	2	32	8	23
	80A		Ø71	230	185	140	2	38	8	25
	100A		Ø90	270	220	165	2	42	8	27

Dimensions (mm)

Flange rating		A	D	C	R	f	t	N	d	
DIN	DN50	6 bar	Ø60	140	110	90	3	13	4	14
	DN80		Ø71	190	150	128	3	13	4	18
	DN100		Ø90	210	170	148	3	13	4	18
	DN50	10 bar	Ø60	165	125	102	3	15	4	18
	DN80		Ø71	200	160	138	3	17	4	18
	DN100		Ø90	220	180	158	3	17	8	18
	DN50	16 bar	Ø60	165	125	102	3	15	4	18
	DN80		Ø71	200	160	138	3	17	8	18
	DN100		Ø90	220	180	158	3	17	8	18
	DN50	25 bar	Ø60	165	125	102	3	17	4	18
	DN80		Ø71	200	160	138	3	21	8	18
	DN100		Ø90	235	190	162	3	21	8	22
	DN50	40 bar	Ø60	165	125	102	3	17	4	18
	DN80		Ø71	200	160	138	3	21	8	18
	DN100		Ø90	235	190	162	3	21	8	23

Process connection type table - 7th, 8th and 9th characters

7 th character		8 th , 9 th character			
Code	Connection size	Code	Connection type * *	Code	Flange rating
C *	1/4"	PF	PF	AC	B16.5 Class 150 RF
D *	3/8"	AB	PT	AE	B16.5 Class 150 FF
E *	1/2"	AA	NPT	AD	B16.5 Class 150 RFSF
F *	3/4"	FF	BSPT	AF	B16.5 Class 300 RF
G	1" (25A)	GG	BSPF	AH	B16.5 Class 300 FF
J	1 1/2" (40A)	HH	NPS	AG	B16.5 Class 300 RFSF
K	2" (50A)	JJ	M	AJ	B16.5 Class 600 RF
M	3" (80A)	ZZ	Other	AL	B16.5 Class 600 FF
N	4" (100A)			AK	B16.5 Class 600 RFSF
Z	Other			AS	B16.5 Class 900 RF
				AM	B16.5 Class 900 FF
				AT	B16.5 Class 1500 RF
				AN	B16.5 Class 1500 FF
				AZ	B16.5 Class 2500 RF
				A8	B16.5 Class 150 RTJ
				A9	B16.5 Class 300 RTJ
				AV	B16.5 Class 600 RTJ
				AW	B16.5 Class 900 RTJ
				AX	B16.5 Class 1500 RTJ
				AY	B16.5 Class 2500 RTJ
				KA	JIS 5K RF
				KT	JIS 5K FF
				KL	JIS 10K RF
				KN	JIS 10K FF
				KM	JIS 10K RFSF
				KP	JIS 20K RF
				KR	JIS 20K FF
				KQ	JIS 20K RFSF
				KC	JIS 30K RF
				KU	JIS 30K FF
				KJ	JIS 30K RFSF
				KD	JIS 40K RF
				KV	JIS 40K FF
				KE	JIS 63K RF
				KX	JIS 63K FF
				DA	DIN 6 bar RF
				DB	DIN 6 bar FF
				DC	DIN 10 bar RF
				DD	DIN 10 bar FF
				DE	DIN 16 bar RF
				DF	DIN 16 bar FF
				DG	DIN 25 bar RF
				DH	DIN 25 bar FF
				DI	DIN 40 bar RF
				DJ	DIN 40 bar FF
				ZZ	Other

* Only available with thread connector type of P791, P792

** In case of P792, thread connector type shall be use gauge union (A020 series). Refer to figure A.

Vapor pressure vs Temperature

* Code "F" - Silicone oil

Temperature (°C)	Pressure (Pa)
228	11
244	25
263	84
277	155
380	13332

Filling liquid reference table

14th character

Code	Application	Filling liquid	Temperature range (°C)	Remark
A	Standard	Silicone oil, 10	-30 ~ 150	
B		Silicone oil, 50	-30 ~ 250	
C	Sanitary and Food Service	Mineral oil	-30 ~ 200	FDA Certified
D	Oxygen and Chlorine Service	Halocarbon	-40 ~ 200	
E	Low Temperature Service	ANDEROL® 423	-50 ~ 150	
F	High Temperature and Vacuum Service	Silicone oil	-30 ~ 315	